

MXH push-pull System

Excellent feeding reliability for high demands



The gas-cooled MXH 315PP and water-cooled MXH 420W PP push-pull systems are created for ESAB Robust Feed PP wire feeders.

With easy change between a straight- or 45 degree rotatable swan neck, the MXH push-pull system is designed to ensure best ergonomics in various applications.

The reliable drive system ensures excellent feeding properties. It has minimal, easily exchangeable parts that are easy to access.

- Available lengths: 6 m, 8 m and 12 m
- Permanent, stable feeding by precise feed rolls and high-performance motor
- Turnable and changeable torch-neck with no tools required
- 2 torch neck options:
 - Straight neck
 - 45° bent neck
- Quick change of feeder rolls without tools
- 2 potentiometers for easy remote access to wire-feed speed and voltage settings.

Visit **esab.com** for more information.



Industry

- Automotive
- Pressure Vessels
- Ship/Barge Building
- Tank and Vessel Fabrication



2 potentiometers for easy access to adjust wire-feed speed and voltage.

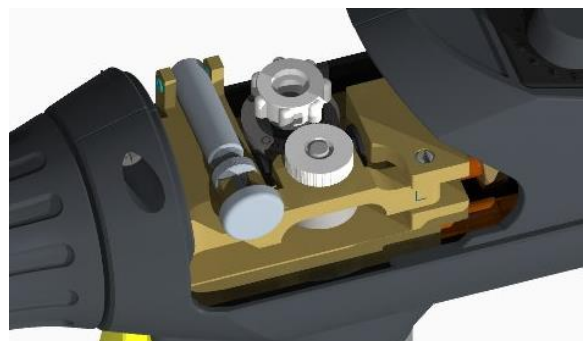

With an easy accessible and strong feeding mechanism the MXH torches feed cables up to 12 m.

MXH push-pull System

Specifications		
Cooling	MXH 315PP	MXH 420wPP
	Gas	Water
Welding Output Mixed Gas	270 A at 60%	400 A at 100%
Welding Output CO ₂	310 A at 60%	430 A at 100%
Recommended Gas Flow	10-20 l/min	10-20 l/min
Wire Feed Speed	2.5 – 18 m/min	2.5 – 18 m/min
Max supply voltage	24 V	24 V
Wire Diameter	0.8-1.6 mm	0.8-1.6 mm
Certification Mark (Standards)	CE (IEC 60974-7)	
Operating Temperature	-10 to +40 °C	
Cable Length	6 m, 8 m, 12 m	

Ordering Information				
Model	Cooling	6 m	8 m	12 m
MXH 315PP, 0° swan neck	Gas	0700025371	0700025304	0700025305
MXH 315PP, 45° swan neck	Gas			0700025306
MXH 420wPP, 0° swan neck	Water	0700025372	0700025307	0700025308
MXH 420wPP, 45° swan neck	Water			0700025309

Delivery content includes PA bronze liner + PA liner for cable assembly, M8x37 contact tips for 1.2 mm wire and feed rolls 1.2mm.

Options & Accessories		
	Required for	
MXH Resistor kit for 3004 feeders (manufactured 2016 ->)	ESAB Aristo Feed 3004	0700025359
Miggytrac / Railtrac / PP remote adapter kit	ESAB Aristo Feed 3004	0459681880
Syntronic 3 synchronization device for alternative feeders MXH	Alternative feeders	0700025311

For wear & spare parts, please see separate instruction manual.

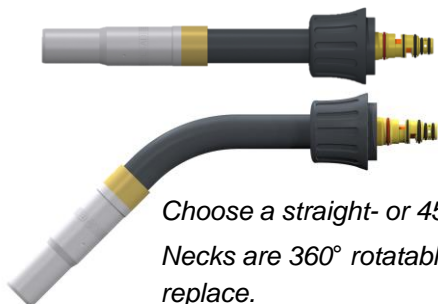

Choose a straight- or 45° bend neck.
Necks are 360° rotatable and easy to replace.



The Syntronic 3 is a synchronization unit.
This allows the MXH push-pull to work with alternative feeders.



ESAB / esab.com

